

# Terminal Block, Header

## STB1001V-7.62-XX

### Description

The STB1001V-7.62-XX is a Terminal Block Vertical Header with a 7.62 mm pitch. The connector is available from 2 up to 24 poles and optionally with a Horizontal.



### Typical applications

- Wire to Board
- Board to Wire

### Features

#### Mechanical Properties

#### Description

Connector Type	Header
Orientation	Vertical
Dimensions	(Poles *7.62) x 12.0 x 8.6 mm ± 0.2
Operating Temperature Range	-40°C~+105°C
Pitch	7.62 mm
Poles	2-24 Poles
Insulator body	PA66, UL94V-0
Pin header	Copper Alloy, Sn plated

#### Electrical Properties

#### Description

Standard	UL	IEC
Rated Voltage	300V	400V
Rated Current	15A	20A
Withstanding Voltage	AC 1600V / Min.	

# Terminal Block, Header

STB1001V-7.62-XX

## Dimensions

\*unit: mm, N= number of poles

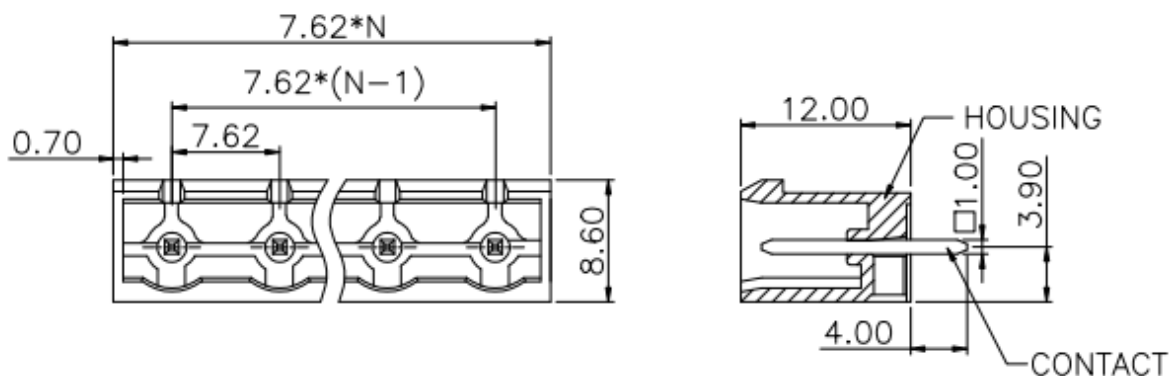

## PCB Footprint

\*unit: mm , N = number of poles

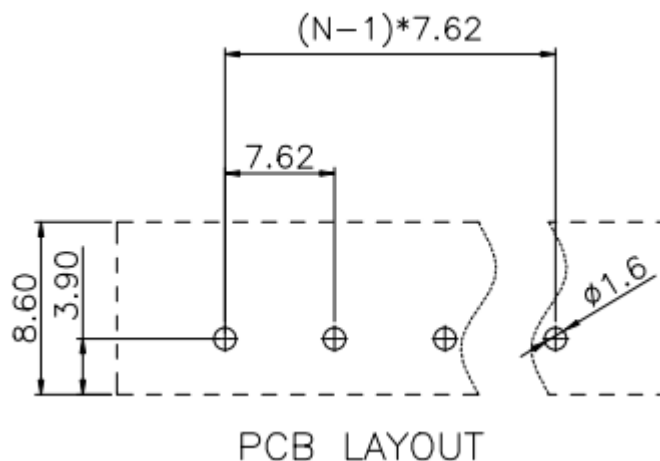

<b>Pole</b>	<b>2</b>	<b>3</b>	<b>4</b>	<b>5</b>	<b>6</b>	<b>7</b>	<b>8</b>	<b>9</b>	<b>10</b>	<b>11</b>	<b>12</b>	<b>13</b>
<b>Length</b>	15,2	22,9	30,5	38,1	45,7	53,3	61	68,6	76,2	83,8	91,4	99,1
<b>Pitch</b>	7,6	15,2	22,9	30,5	38,1	45,7	53,3	61	68,6	76,2	83,8	91,4
<b>Pole</b>	<b>14</b>	<b>15</b>	<b>16</b>	<b>17</b>	<b>18</b>	<b>19</b>	<b>20</b>	<b>21</b>	<b>22</b>	<b>23</b>	<b>24</b>	
<b>Length</b>	106,7	114,3	121,9	129,5	137,2	144,8	152,4	160	167,6	175,3	182,9	
<b>Pitch</b>	99,1	106,7	114,3	121,9	129,5	137,2	144,8	152,4	160	167,6	175,3	

# Terminal Block, Header

STB1001V-7.62-XX



## Part number

**STB1001X-XXX-XX**

<b>STB1001</b>	Style of connector
<b>V</b>	Vertical
<b>7,62</b>	Pitch
<b>XX</b>	Poles 2,3,4,5,6,7,8, 9,10, 11,12, 13,14,15,16,17,18,19,20, 21,22,23,24

## Ordering information

Ordering can be done via [www.summit-electronics.com](http://www.summit-electronics.com) or via [info@summit-electronics.com](mailto:info@summit-electronics.com). Please contact us for more information. Customisation of the product is available on request.

## Technical support

For all product questions please contact us via [info@summit-electronics.com](mailto:info@summit-electronics.com)

## Document revision

Rev	Date	Changes
<b>V01.00</b>	06-04-2023	First issue of document